



Be Crafty.

Technique Tutorial

How to Apply a Magnetic Snap

Magnetic fasteners are great for totes, purses and even apparel! Round snaps are available in two sizes – 1/2" and 3/4" diameter. Square styles are 3/4". Both are available in silver and gold. The process of attaching magnetic snaps is pretty easy. Mark the position, cut the slits for the prongs. Mount the pieces and fold the prongs. Done. But there are tips and secrets to having the finished item wear well.

You've never used a magnetic snap? Well, let us show you the basics. Tips included, of course!

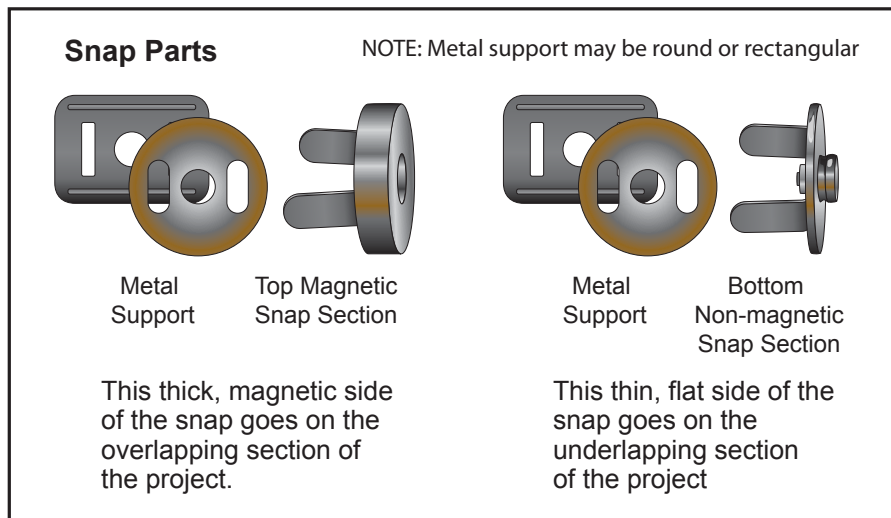

You will need:
1 set of magnetic snaps
Sharp scissors
Pliers
Marking pencil
Your project
Iron-on interfacing

Optional for Totes & Purses:
Lightweight cardboard or plastic canvas
Fusible fleece

Optional for Apparel:
Fusible fleece
Thread to match garment

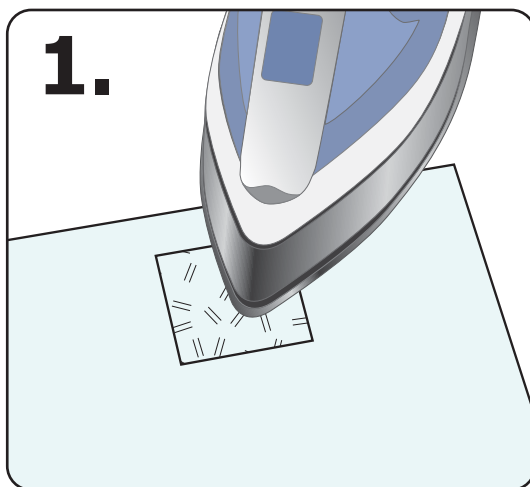

1.

1. Always use interfacing under the snap.

For apparel, cut a 1 1/2 – 2" square of medium to heavy weight iron-on interfacing. Center it over the intended snap location on the wrong side of the fabric. Press to fuse.

For totes and purses cut a 1 1/2 – 2" square of heavy weight iron-on non-woven interfacing. Center it over the intended snap location on the wrong side of the fabric. Press to fuse.



Be Crafty.

Technique Tutorial

How to Apply a Magnetic Snap (continued)

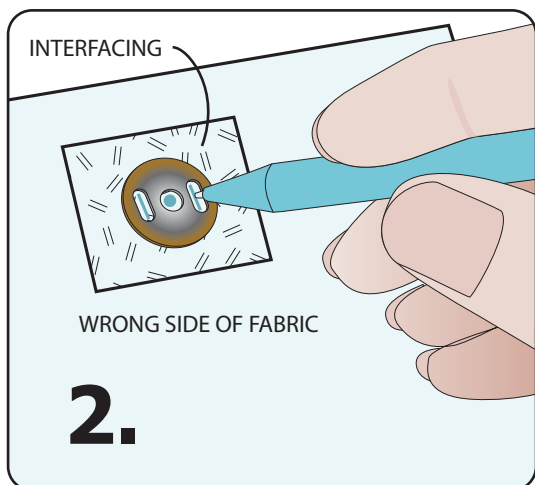

2. Mark the snap position. Use the metal support as your guide. Mark the center of each corresponding snap position, making sure the center points line up. Then mark the small rectangular holes on each side of the center hole. These are for the prongs.

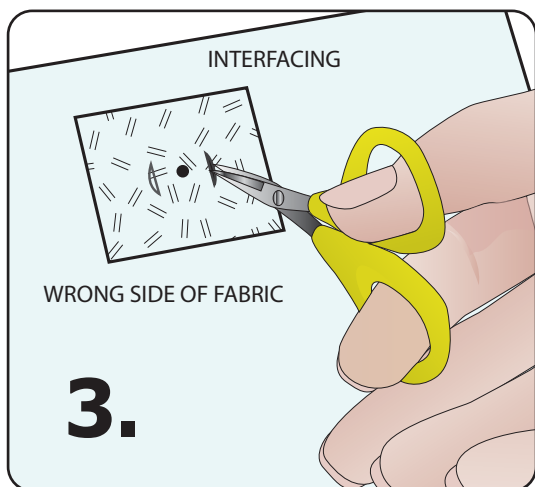

3. Use very sharp, small scissors to cut the prong holes. Keep the cut as small as possible.

ALTERNATE METHOD:



Use a sharp ripper to cut the holes for the prongs. Place a straight pin at each end of the mark. Insert the ripper point at one end, and push forward. The straight pins will prevent the cut from going too far.

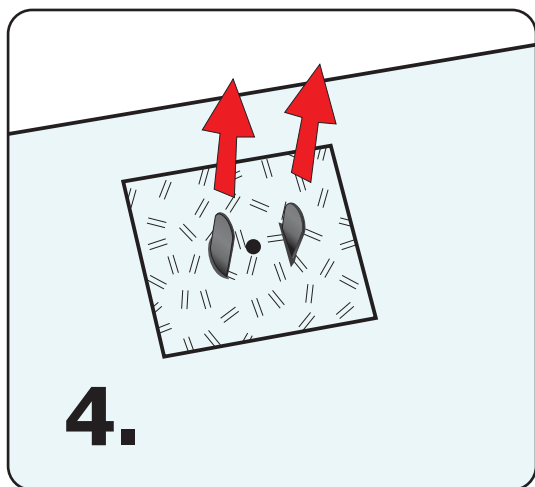

4. Insert the prongs through the slits from the right side to the wrong side of the fabric.

TIP



Use Fray Check™ on the slits to prevent raveling.



Be Crafty.

Technique Tutorial

How to Apply a Magnetic Snap (continued)

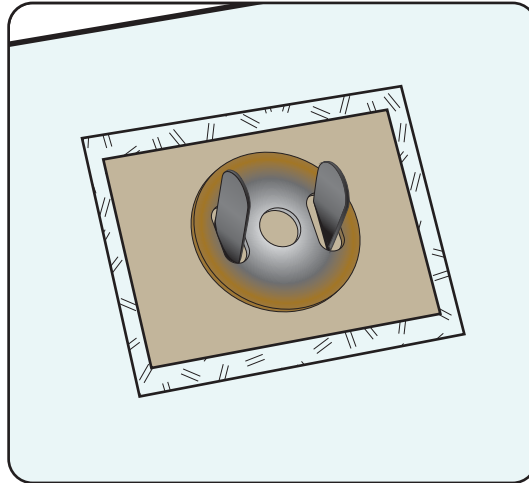
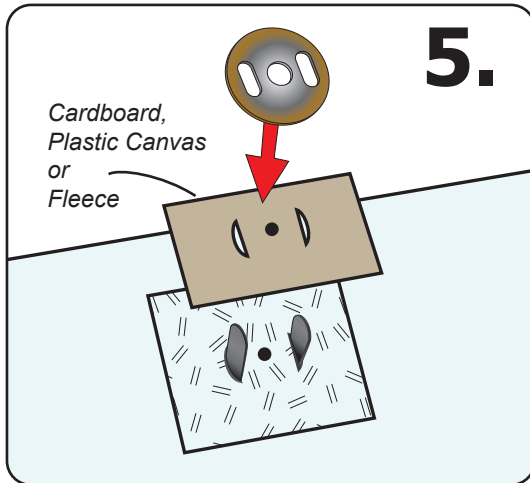

5. Place the cardboard and the metal support over the prongs. See the tip for important information!

TIP for TOTES & PURSES



Added support may be needed for totes and purses. Before attaching the metal support add a layer of lightweight cardboard or plastic canvas to add strength and to prevent the metal support or the extended metal prongs from damaging your fabric. Cut the cardboard, plastic canvas or fleece about 1" high x 1 1/2" wide. Mark and cut slits as in steps 2 and 3. Slip this added layer over the prongs, then slide on the metal support. Flatten the prongs as in step 6.

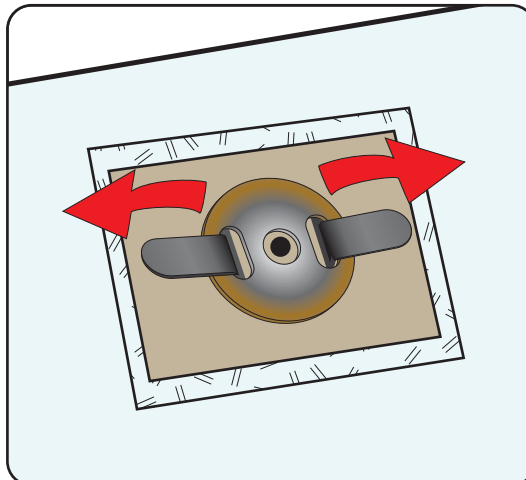
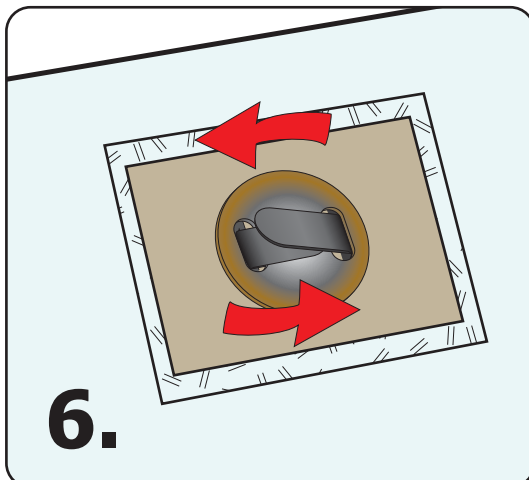

6. Use pliers to bend the prongs flat. They can be bent toward the center of the snap, or they can be bent outward away from the snap.



Be Crafty.

Technique Tutorial

How to Apply a Magnetic Snap (continued)

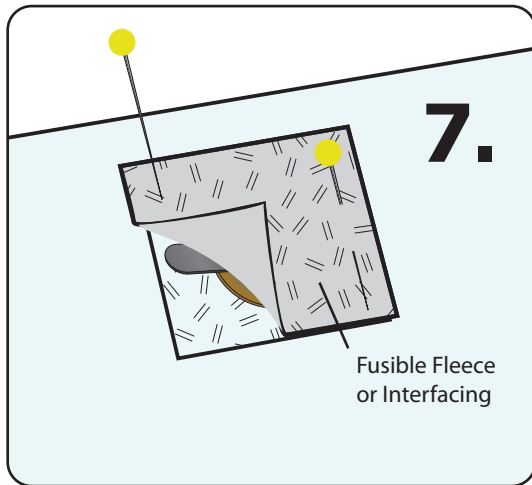

7. Always fuse iron-on interfacing to any surface that may rub against the back of the snap. This is on the inside of the project and will not show.

In addition, when not using cardboard or plastic canvas for strength and protection, (See step 5 Tip) you can also fuse interfacing or fusible fleece directly to the flattened back of the snap.